

The background features a dark blue color with several white circular gauges and arrows. One large gauge on the left has numerical markings from 140 to 260 in increments of 10. Other gauges are partially visible, some with arrows indicating clockwise or counter-clockwise rotation. The overall aesthetic is technical and modern.

FLOOD WARNING SYSTEMS

MARK MOORE

NHWC DIRECTOR AT LARGE

Agenda

- Just what is the NHWC (National Hydrologic Warning Council)?
- The warning process and flood warning systems
- ALERT, ALERT₂, and how we send data
- Measuring rainfall in real time
- How CoCoRaHS helps to save the day

Vision

For all communities to effectively use hydrologic information and warnings to protect lives, property, and the environment.

Mission

To provide education, training, and standards for the generation, delivery, and use of timely reliable hydrologic information.



Hydrologic Warning

The ability to warn of imminent danger to life, property, and the environment from hydrologic disasters through the use of automated remote data collection networks, modeling and analysis, and integrated forecast and warning systems



The Warning Process

Observe, monitor,
detect, forecast and
generate warning



Disseminate warning

Respond
Appropriately

Technical Areas

- Hydrology
- Data Collection
- Modeling & Analyses
- Standards and Guidance
- Hazard Communication & Public Awareness



NHWC Newsletter



The NHWC Transmission

October 2017

CONTENTS

- Hurricane Harvey 1
- City of Salem FWS 3
- CoCoRaHS Update 5
- US Hydrologic Conditions 6
- Calendar of Events 7
- November Focus 7
- Parting Shot 7

Click on hyperlinks located throughout this newsletter for more information.

NHWC 2017-19 Officers and Directors

Steve Fitzgerald
President
Harris County FCD

Joshua McSwain
Vice President
Charlotte-Mecklenburg Stormwater Services

Brad Heilwagen
Secretary
Amec Foster Wheeler

Ben Pratt
Treasurer
Susquehanna River Basin Commission

Bruce Rindahl
AUG Representative
Ventura County Watershed Protection District

Directors At-Large

Jimmy Stewart
SunWater

Fritz Law
OneRain Incorporated

Andrew Rooke
AMR Consults, LLC

Kevin Stewart
Urban Drainage and FCD



The Untold Story of Hydrologic Data Collection for the Harris County Flood Control District during Hurricane Harvey

Mark Moore, Harris County Flood Control District

The Harris County Flood Control District (HCFCDD) fully converted to ALERT2 in December of 2015, and since then has presented several articles describing the success of the new technology and its implementation. Repeating the same statistics and figures would only provide so much value, so instead we would like to focus on sharing some lessons we have learned from Hurricane Harvey.

ALERT2

For the full story on the HCFCDD conversion process to ALERT2, reference *Harris County Flood Warning System 2016 Tax Day Flood Test – Passed!*¹ The analysis from Harvey shows similar success for the 154 gages in the system. Over the five days around the event, the ALERT2 network collected 250,000 data points with over 99% of incoming data successfully received. The system sent out over 500 valid alarms indicating intense rainfall rates or flooding conditions.

System Hardware

Over half of Harris County's 22 watersheds experienced record breaking flood levels, and as expected for such an epic event the gage network suffered damage. To put into perspective the magnitude of rainfall that Harvey produced, an average of 33.7 inches of rainfall occurred across Harris County's 1,777 square miles – equaling 1 trillion gallons of water and produced 68% of the annual average rainfall for the City of Houston in a four-day period. Only seven of the 154 gages sustained flood damage. In addition, five other sites had damaged water level sensors and two additional sites reported unreliable rain. All major repairs were completed by September 14th (14 days after rain stopped) due to the hard work of David Haynes, Don Van Wie, and HCFCDD Technicians, restoring the system to full functionality to be prepared for the next flood event. Flooding from previous storm events encouraged HCFCDD to raise gages to higher locations, and two of the three sites that flooded during Harris County's last storm did not flood during Hurricane Harvey. However, some of the damage may have been prevented with better installation procedures.

Two of the flooded sites are located close to the banks of the San Jacinto River, and have had consistent issues with flooding in past events. Repair work included elevating both stations and installing all equipment as high as possible (Figure 1). Every site that flooded was modified in some way to make the system more flood resilient for future storm events.

¹ M. Moore, S. Fitzgerald, J. Lindner. *Harris County Flood Warning System 2016 Tax Day Flood Test – Passed!* The NHWC Transmission, October 2016



Figure 1. Flood gage along the banks of the San Jacinto River. Storm debris can be seen all the way to the top of the antenna mast. Repair work involved elevating equipment to prevent damage from future minor floods.

to the primary data collector located at the radio tower. All data from other servers was transferred over to the cloud hosted server, and redundancy was successfully restored thanks to the diligent work of OneRain staff.

The Public Website

The HCFCDD maintains and operates our FWS website to provide accurate and reliable real-time rainfall, flood stage, and other data. This information is used by the HCFCDD and by Harris County's Office of Homeland Security and Emergency Management to inform the public of imminent and current flooding conditions along watercourses. The website serves as a direct access point for public users, and was heavily utilized during the event.

Over 1 million unique users visited the website during Harvey, with over 6.3 million different page views (6x higher than any previous event). This load on the website caused the entire page to crash several times during the event even with

HCFCDD Servers

The flood gages themselves were not the only part of the network that experienced issues during Harvey's flooding. During the event HCFCDD was informed that Harris County IT might be forced to change the network pathways for our primary server location due to flood damage. This would potentially stop the ability to transfer data to the Flood Warning System (FWS) website from the data collection point (Figure 2, Point A). At 10:30 AM August 28th, a conference call was held to ensure that vital processes could be handled by the backup server at a separate location. At 11:05 AM August 28th, 35 minutes later, the backup server failed due to internet connection issues at the unmanned secondary receive site due to storm damage (Figure 2, Point B). This was the only backup for the threatened primary server.

Fearing loss of data connections from the primary and backup servers, we contacted OneRain, HCFCDD IT staff, and Harris County IT staff. We proposed a cloud hosted server as a "third" backup location. At 3:32 PM August 28th (~4.5 hours after our backup site failed), OneRain completed setup of a cloud sever that connected

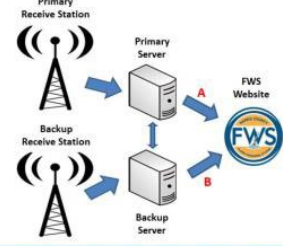

Figure 2. Diagram of flood warning data after it has arrived at the radio towers. Concerns were raised about the connection at Point A. Point B failed 35 minutes later.

preventative measures. A review of the statistics from the FWS website revealed a few key pieces of information that all flood warning system operators should be aware of:

- 65% of users went to the website on a tablet or mobile device.
- 35% of visitors were new users.
- Most users went to the website directly or from a google search (70%), but other websites such as news agencies (20%) and



Board Members

Bruce Rindahl, President	Denver, Colorado
Brad Heilwagen, Vice-President	Nashville, Tennessee
June Wolfe, III, Secretary	Temple, Texas
Ben Pratt, Treasurer	Lancaster, Pennsylvania
James Stuart	Queensland, AUSTRALIA
Mark Moore	Austin, Texas
Matthew Friedberg	Las Cruces, New Mexico
Rob Hartman	Roseville, California
Fitz Law	Longmont, Colorado



2010 MEMBERSHIP SURVEY RESULTS

- *RANK the following NHWC PRIMARY FUNCTIONS 1 to 5 in order of importance with '1' being highest. Please use each number only once.*
 - 2.53 *Provide technical training through workshops.*
 - 2.76 *Build community capacity to collect and use data for early detection and warning of hydrologic events.*
 - 2.83 *Facilitate coordination at the federal, state, and local levels along with academia and the private sector.*
 - 3.03 *Provide public outreach to communicate risk to hydrologic hazards and benefits of hydrologic warning systems.*
 - 3.26 *Be the national voice for local and regional hydrologic warning system user groups.*



2010 MEMBERSHIP SURVEY RESULTS

- *The NHWC is developing programs to meet the training and professional development needs of its members. What training format do you prefer?*

41% Local workshop

33% Online webinar

16% Conference setting

10% Downloadable resources



What can you do for NHWC?

- **Serve On Conference Committee**
- **Take Part In An NHWC Committee**
 - **Hydrology, Data Collection, Training & Professional Development, Etc.**
- **Write An Article For The Newsletter**
- **Participate In The Forum**
- **Help Neighboring Agencies**



What can NHWC do for you?

- National Representation
- Training/Continuing Education
- Technical Conferences
- Technical Workshops/Webinars
- Reduced Fees
- Email Updates
- Newsletters
- Publication Library



The background features a dark blue color with several white circular gauges and arrows. One large gauge on the left has a scale from 140 to 260. Other gauges are smaller and scattered across the page. Arrows indicate various directions of movement, some clockwise and some counter-clockwise.

FLOOD WARNING SYSTEMS

CRS SYSTEM LEVELS

- **Level 1: Manual flood threat recognition systems.** A manual system relies on a person to interpret the data received from river and/or tide gages, often using paper tables or graphs. In many cases, the gage data are collected and reported manually, usually by volunteers.
- **Level 2: Automated flood alarm systems.** These systems issue a signal when a flood threatens. When water reaches a certain height on a river or tide gage, an alarm is sent to the monitoring location. Unlike automated flood warning systems (credited as Level 3), Level 2 systems do not predict flood heights or provide any data other than the current water level.
- **Level 3: Automated flood warning systems.** These systems provide information such as the timing and potential crest of an oncoming flood. On larger rivers, they may be operated by the NWS and the U.S. Geological Survey. Where there are flash floods on smaller rivers, a local ALERT system or IFLOWS (Integrated Flood Observing and Warning System) may be established.

FLOOD WARNING SYSTEM GOAL (EXAMPLE)

EXAMPLE: Provide accurate and consistent rainfall, stage, and other data on a reliable real-time basis in a useful form to local, regional, and federal agencies and the public to facilitate making decisions before, during and after storm events to reduce the risk of property damage, injuries, and loss of life.

PLANNING - EXISTING FLOOD HAZARDS

- Local watershed flooding
- Riverine flooding
- Dam break
- Levee break
- Coastal flooding (tropical storm, sea level change)
- “Flashy” watersheds?
- Historical records
- Increasing hazards



SYSTEM COMPONENTS

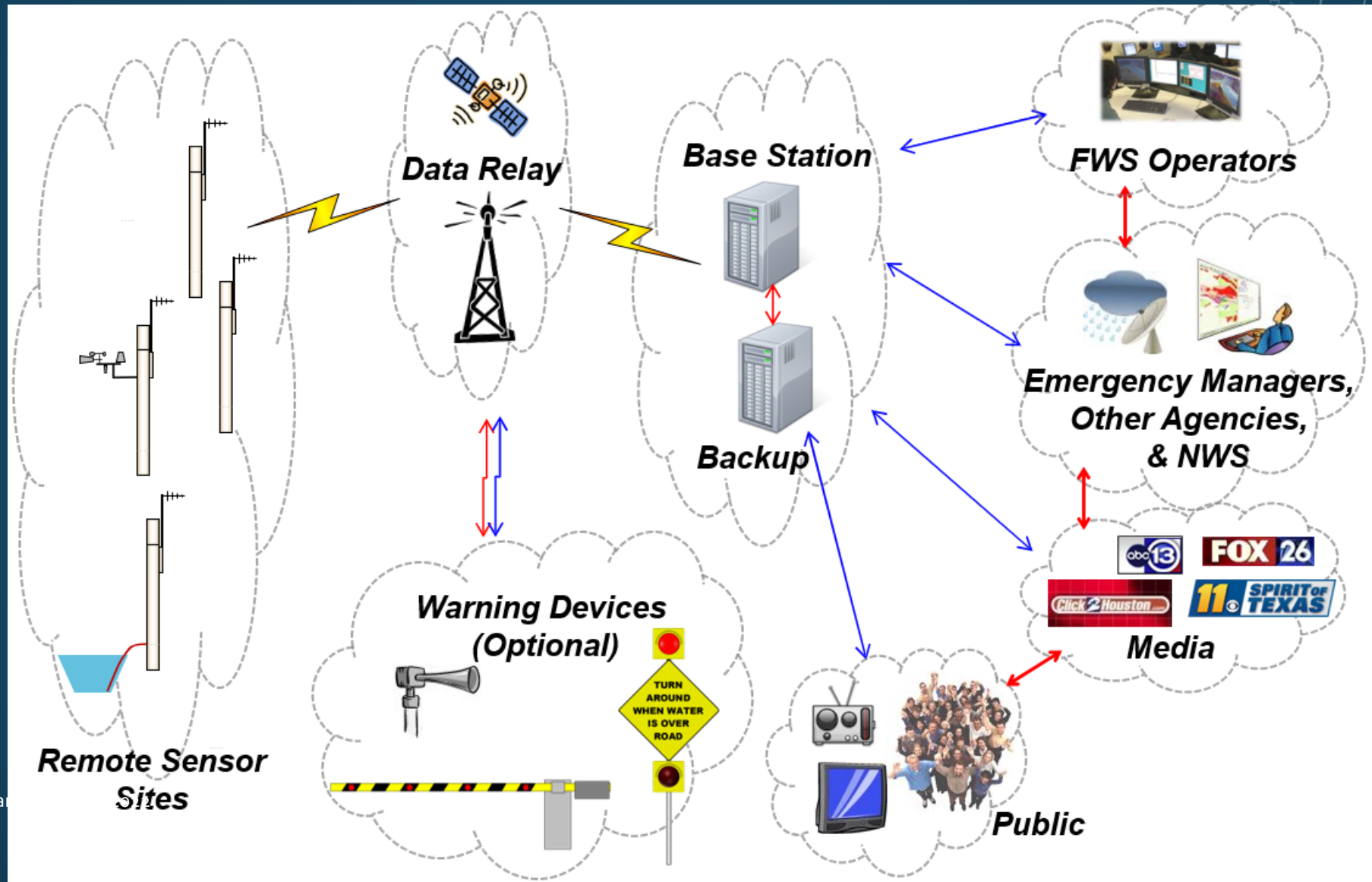

PRECIPITATION MONITORING

- Remote Sensing
 - Satellite
 - Radar
- In Situ Measurement
 - Automated gauges
 - Field observers

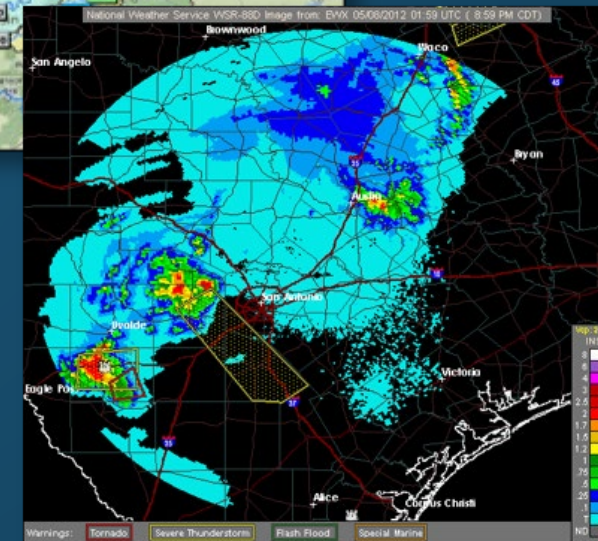
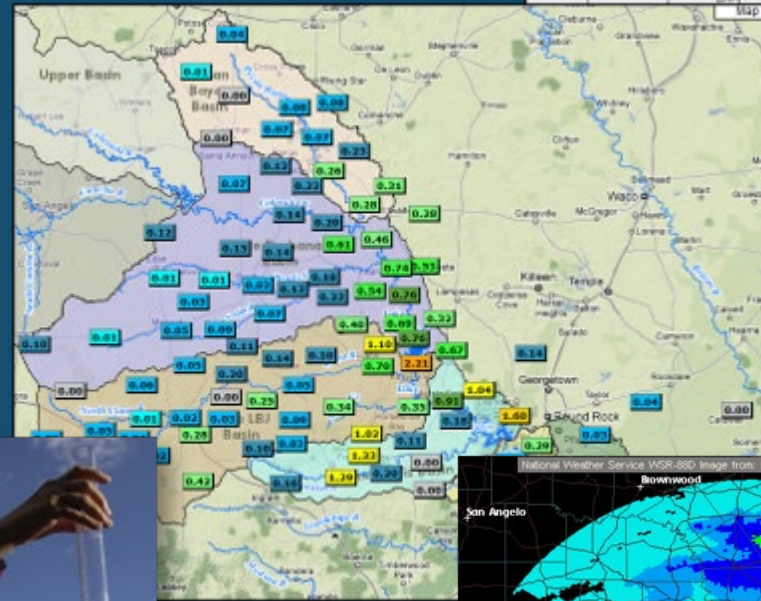
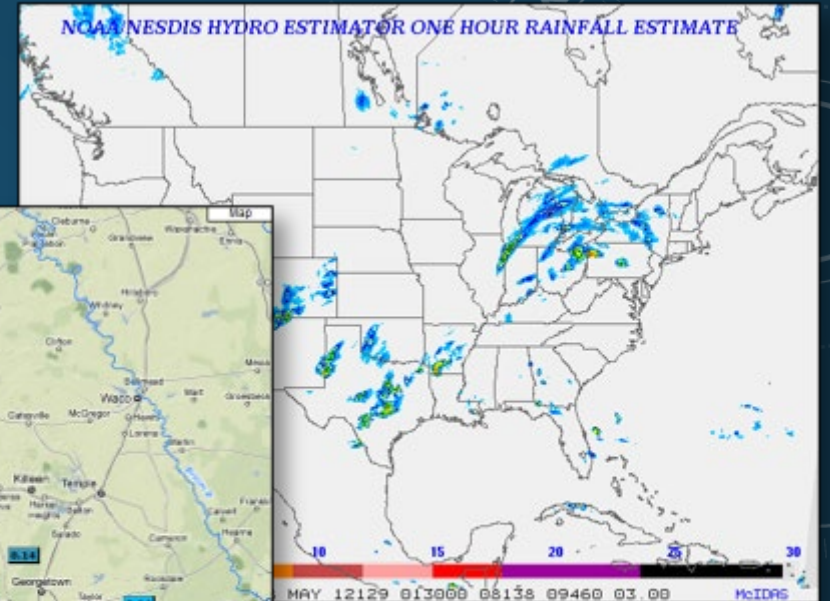

STREAM RESPONSE MONITORING

- Automated gages
- Field observers
 - Wire weight gage
 - Staff gage
 - Post event survey

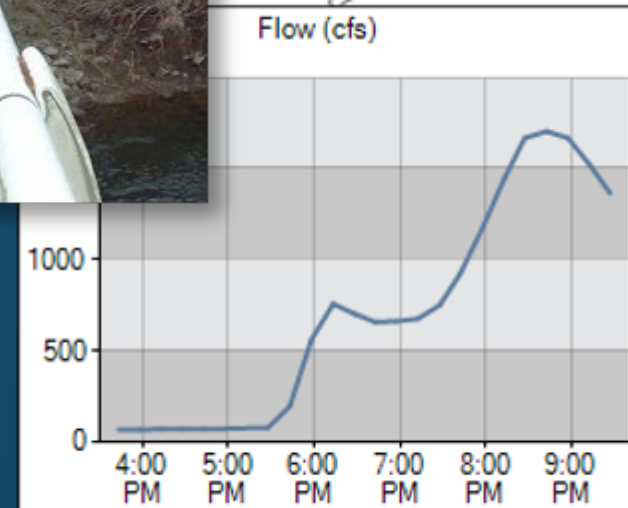
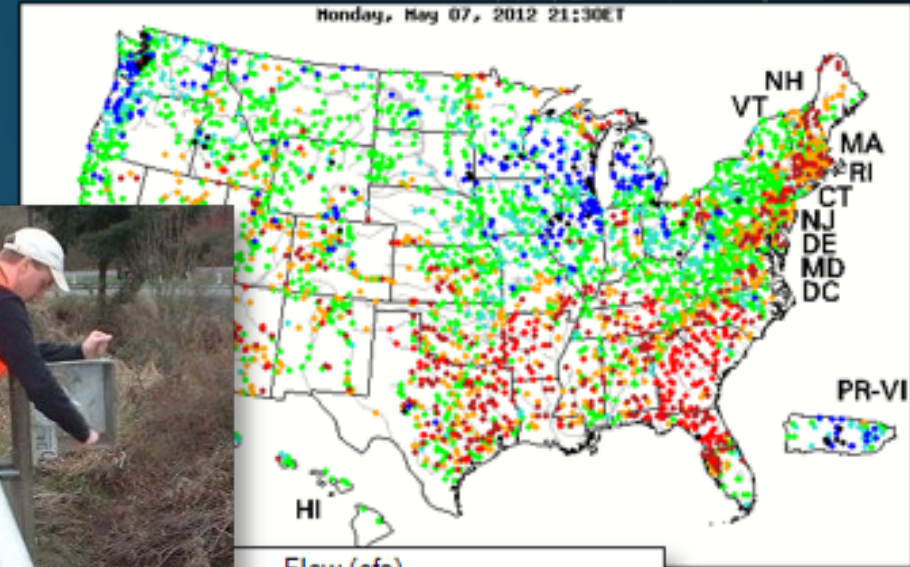
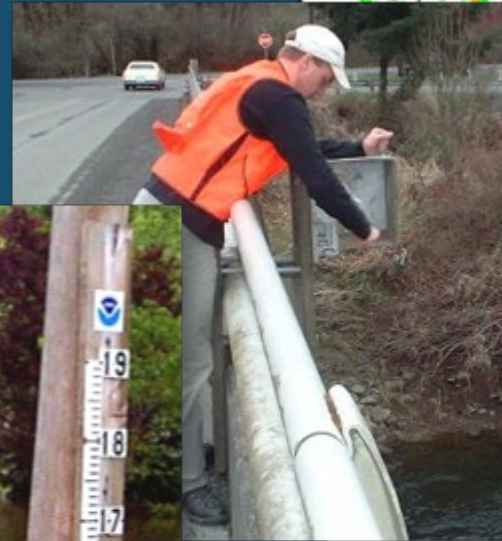

WATER LEVEL SENSORS

- **Types**

- Pressure Transducer
- Bubbler
- Stilling Well & Float
- Radar
- Ultrasonic

- **Placement**

- Upstream or downstream?
- Impact protection
- Bridge pillar or other impacts

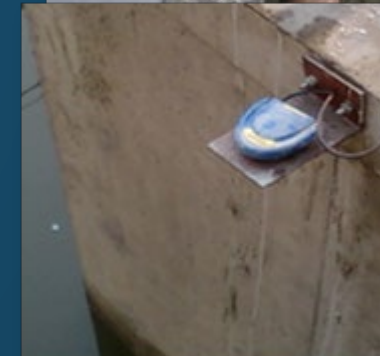

SITE CONSIDERATIONS

- **Access**
- **Security**
- **Data accuracy**
- **Other considerations (housing type, shared site, other sensors, site longevity)**





ALERT AND ALERT₂

- **Automated Local Evaluation in Real Time (ALERT)**
- **Developed in 1970s to remotely report rainfall**
- **One-way, event-based sensing network**
- **Sends data as radio “chirp” on protected frequency**

ISSUES WITH ALERT

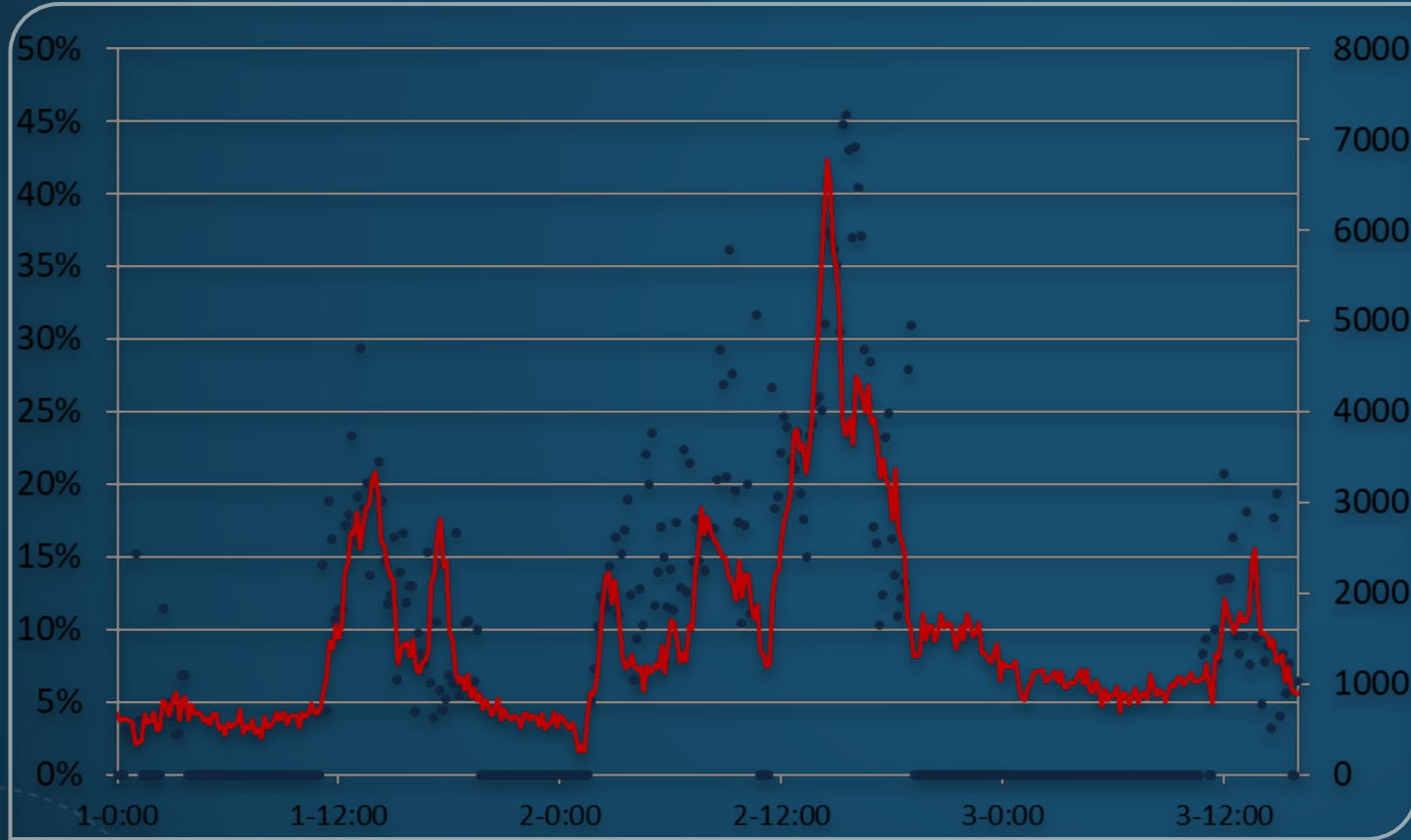

- Can only report integer values (0-2047)
- Loss of data when simultaneous transmissions occur
- Increased likelihood of lost data during weather events

ALERT AND ALERT₂

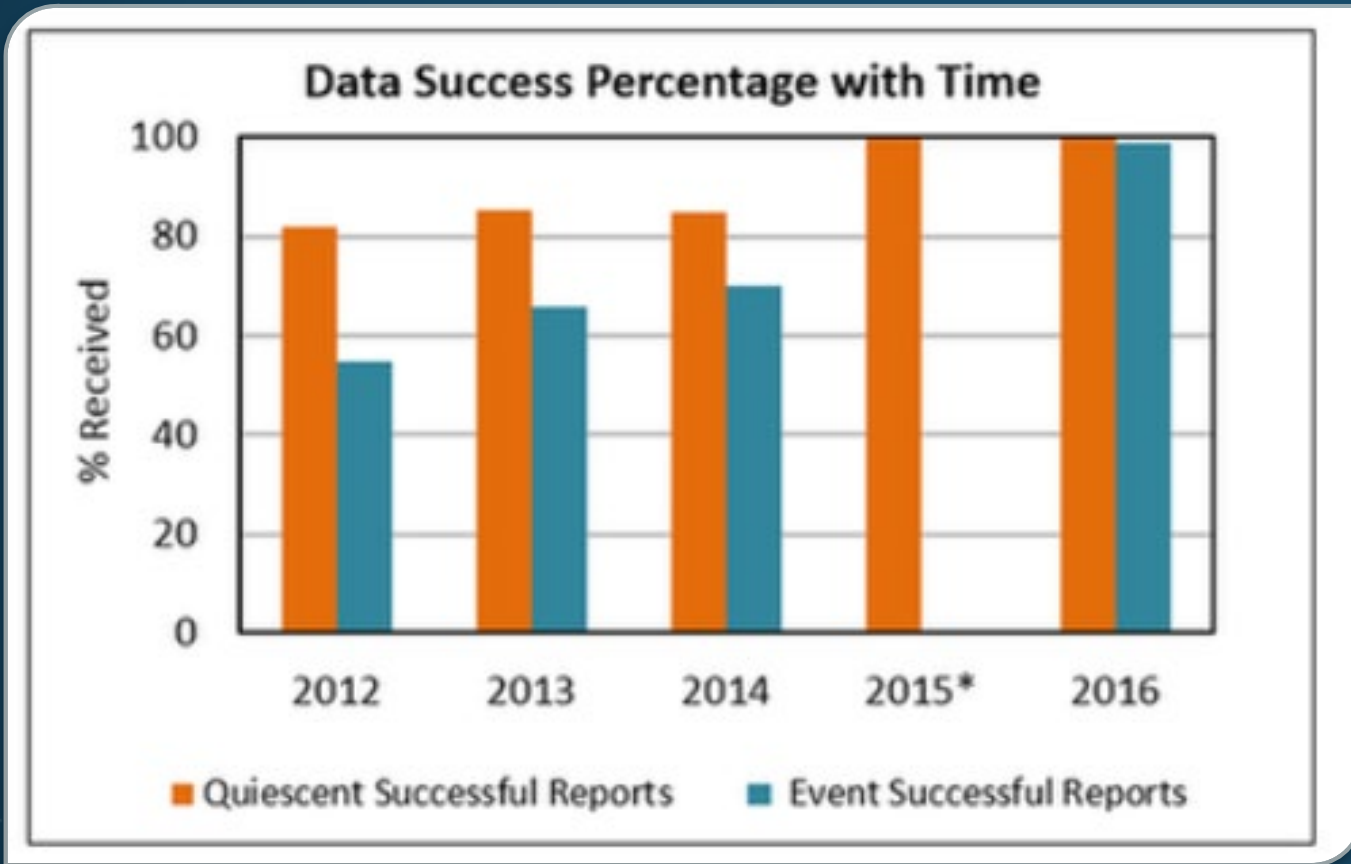

- Each gage must wait for a pre-assigned slot to report
- Data sent in engineering units
- No loss of data during weather events



THE GOOD

When systems are well maintained and improved, citizens take notice.

+7 million page views in one week.

CoCoRaHS Webinar November 2022

Here's how the new inundation flood mapping tool works

Posted: 6:29 PM, June 11, 2018

Updated: 6:32 PM, June 11, 2018

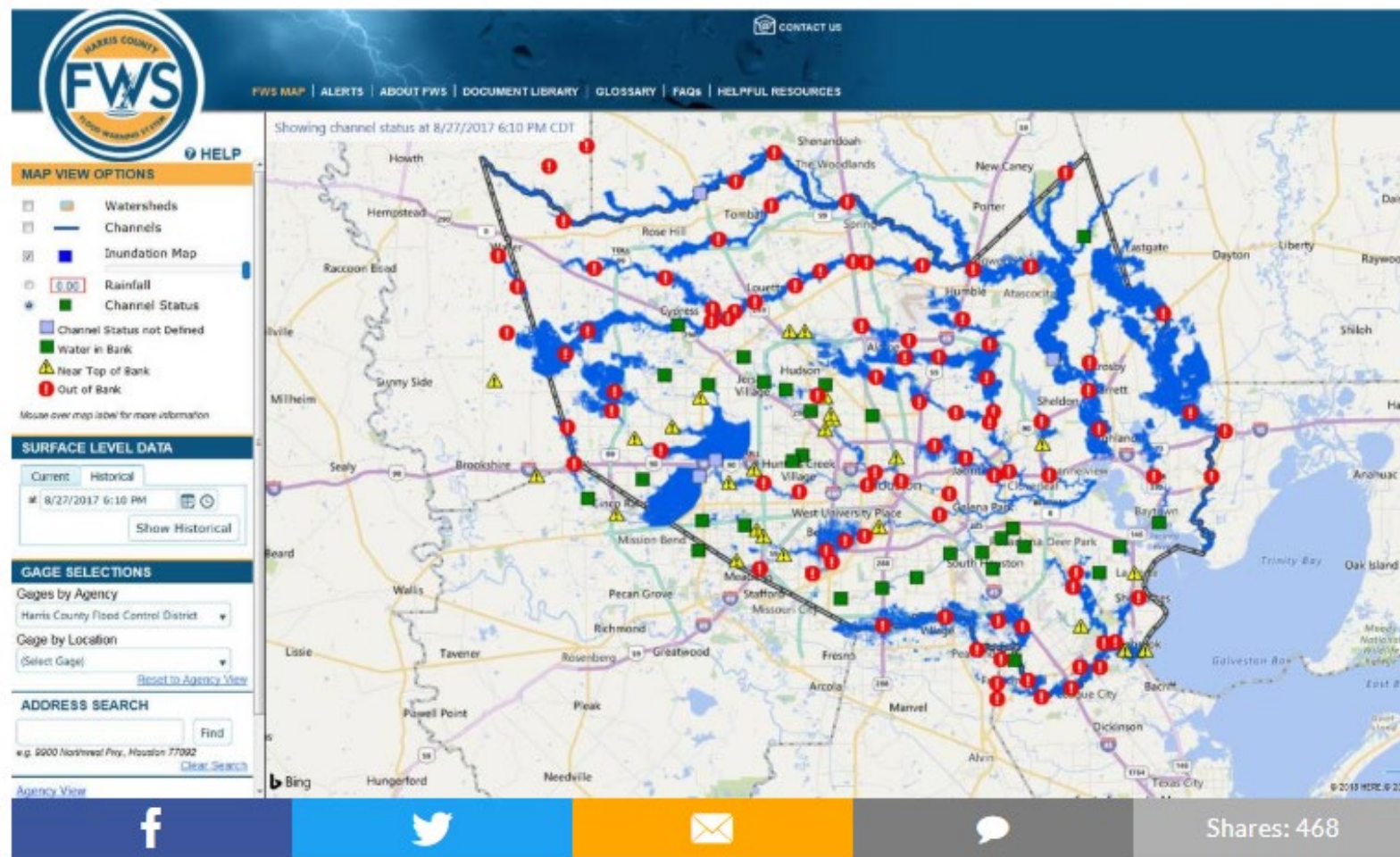

HOUSTON - A new tool showing inundation maps after bayous go out of banks has been unveiled by the Harris County Flood Control District.



THE BAD

When a single gage goes out or experiences issues, everyone notices.

This reduces trust in the system.

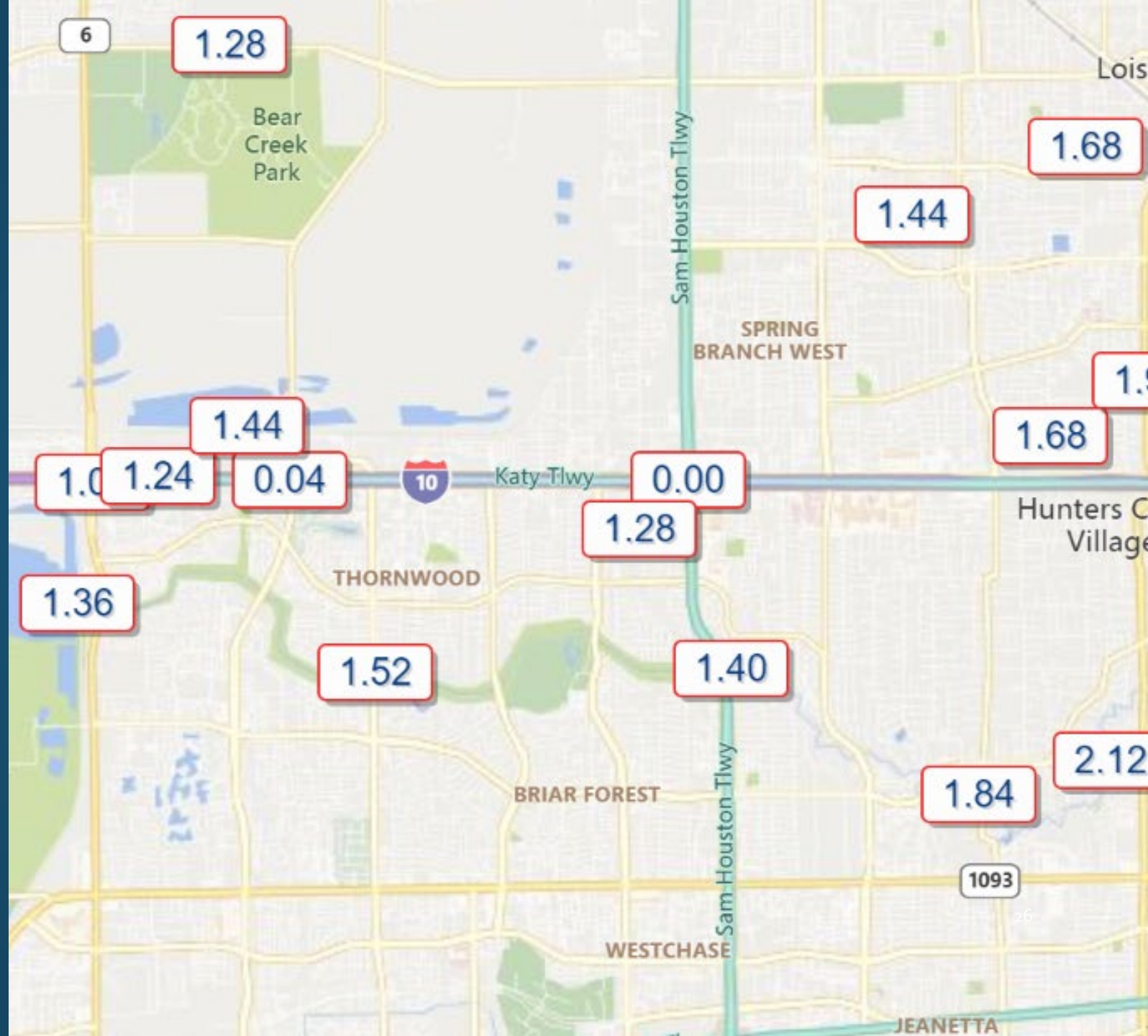



THE UGLY

When people trust your data, they treat it as absolute truth.

Even when it isn't.



Tropical System Total Rainfall Record: **BROKEN**

National Weather Service Houston/Galveston

Previous CONUS record: 48.0 inches

Cedar Bayou at FM-1942: **51.88 inches**

(from August 25th 12:00 AM CDT – August 29th 3:40 PM CDT)

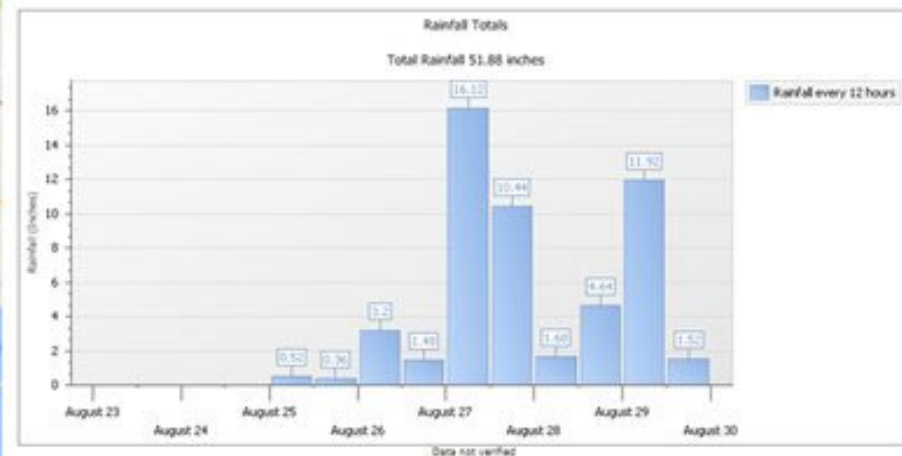
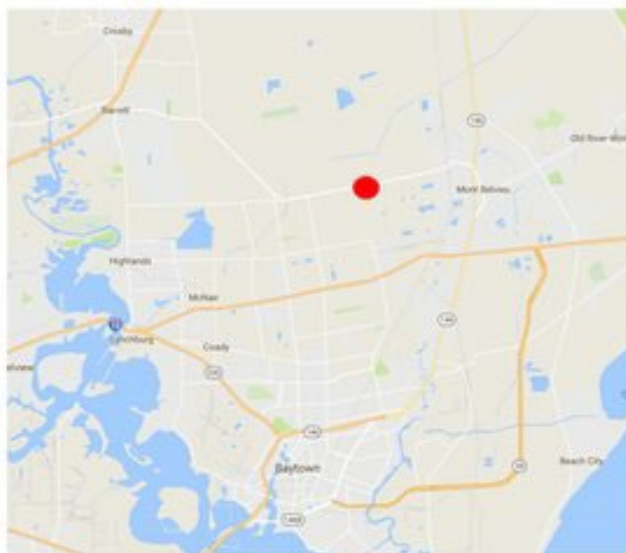

*This is a preliminary report. The gauge may have stopped reporting as of 3 PM CDT.

@NWSHouston

hurricane harvey rainfall 51.88



Image Created:
17 4:05 PM

All News Maps Images Videos More Settings Tools

About 37,200 results (0.57 seconds)

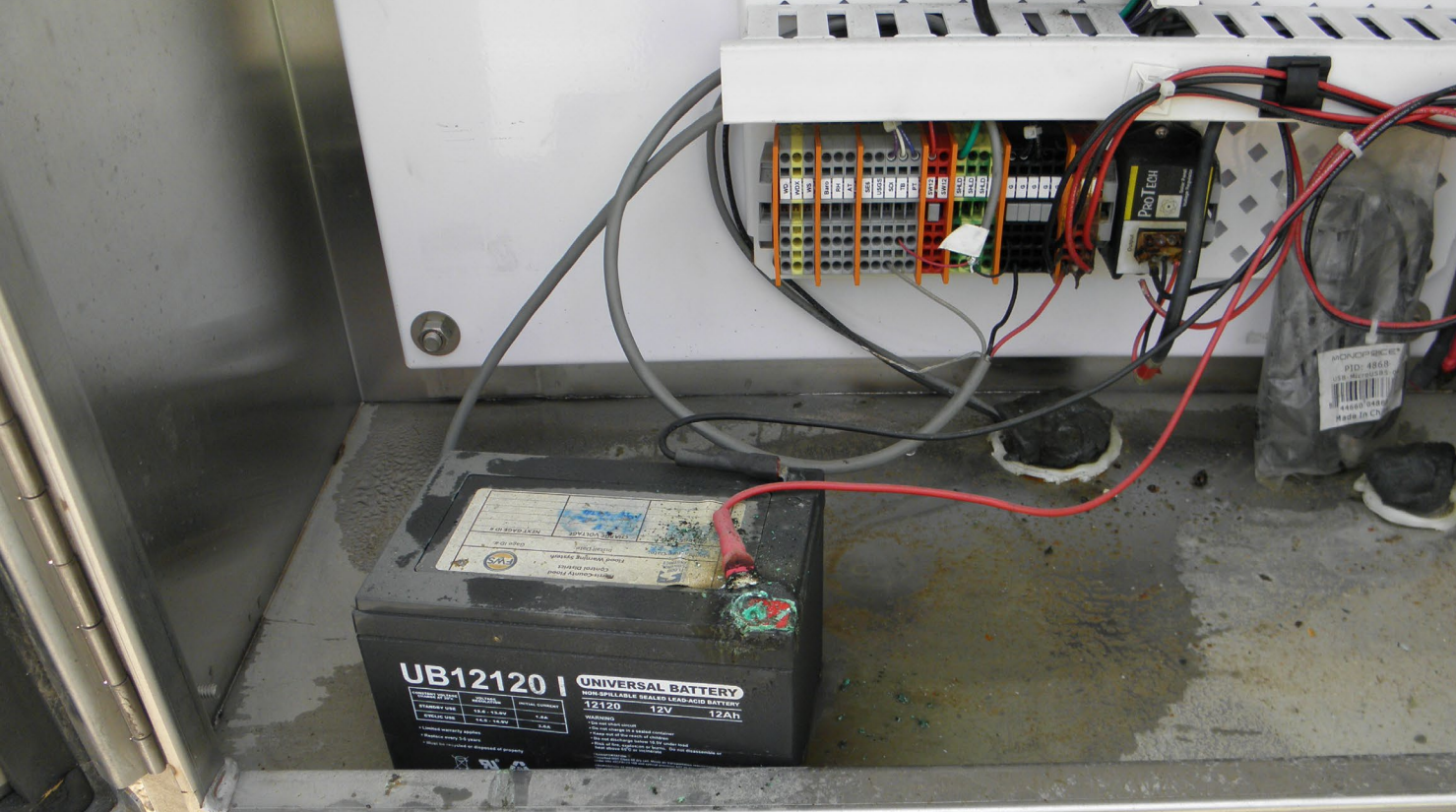

● Markers Legend Zoom Out

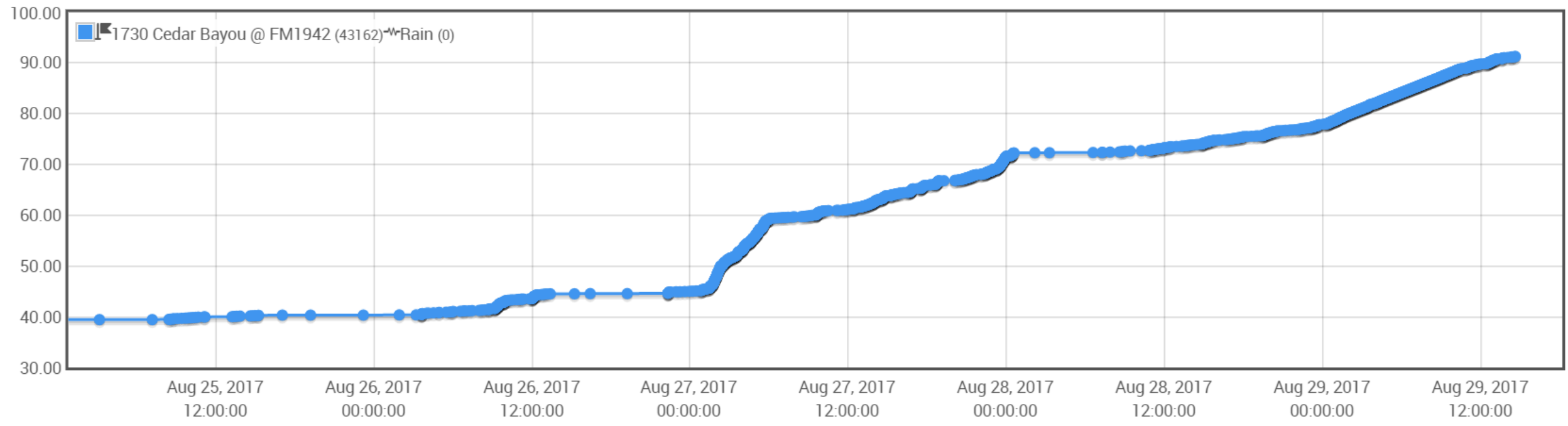

● Markers Legend 🔍 Zoom Out

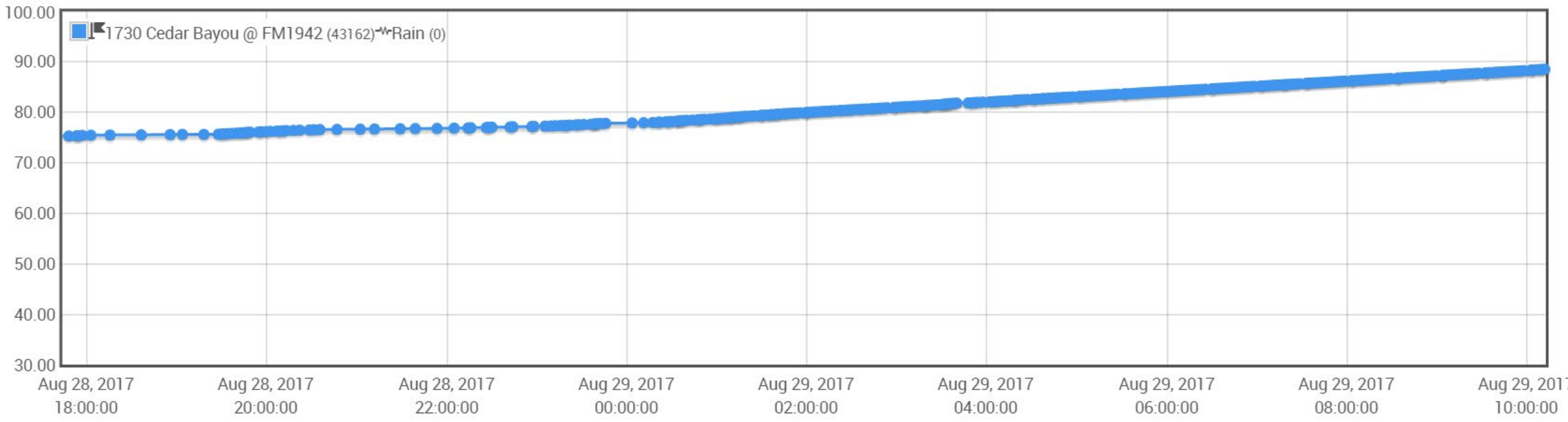

TIPPING BUCKET

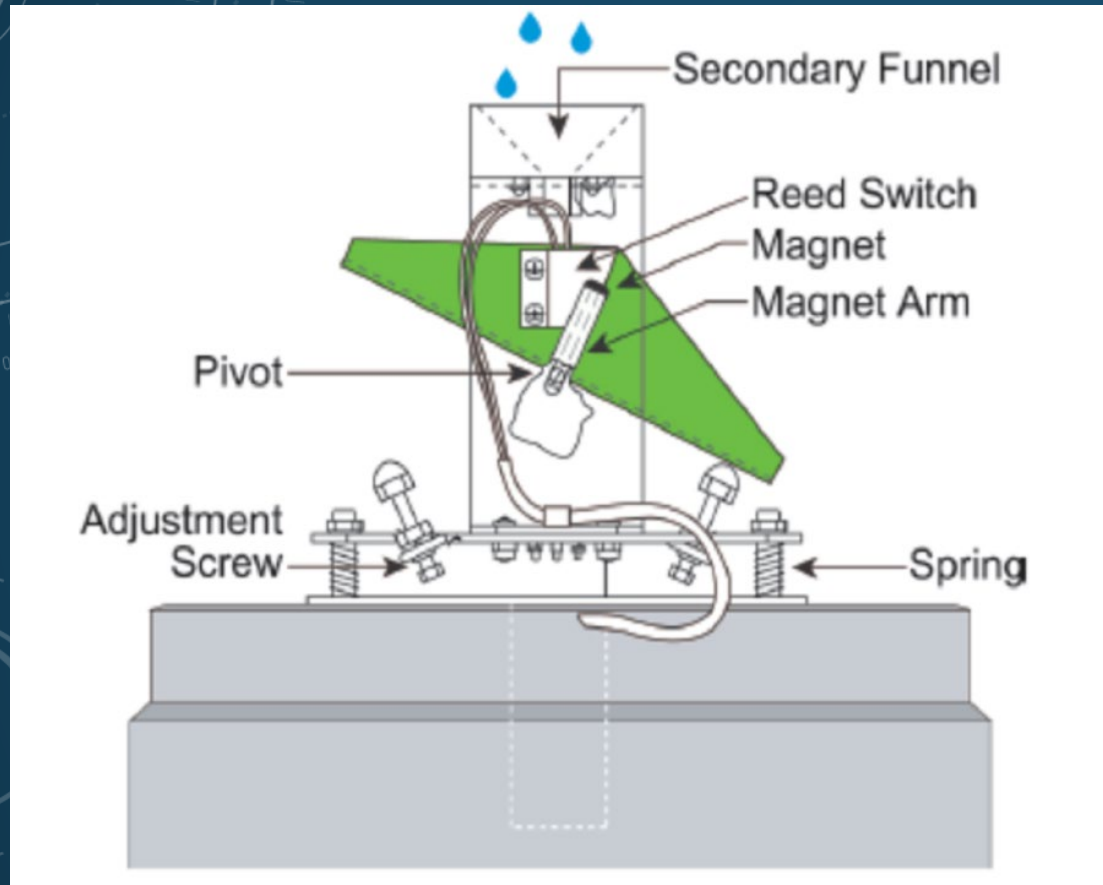

- Rain is funneled into one side of the tipping bucket
- The device counts each time a tip occurs
- Each tip for a HCFCD tipping bucket is ~0.04" of rainfall

ADVANTAGES AND DISADVANTAGES



The Good

- Cheapest option
- Very reliable
- Easy calibration check
- Simple wiring
- Compatible with almost all weather systems

The Bad

- Maintenance heavy
- Funnels clog
- Tipping mechanism can get stuck
- Require regular calibration
- Less accurate with heavy rainfall – misses rain with each tip
- Leftover rain issue



WEIGHING BUCKET

- “Optimal for use” by NWS
- Measures mass of accumulated water
- Precise measurement of rainfall amount and rate

ADVANTAGES AND DISADVANTAGES



The Good

- Most accurate
- Very reliable
- Can calibrate weights
- Easy measurement of snow and hail
- Accurate on all ranges of rainfall rate

The Bad

- Funnels clog
- Must be emptied after a certain amount of rain
- Require regular calibration
- Expensive
- May require more sophisticated logger
- Easy false positives

DISDROMETER



- Measures drop size distribution
- Rainfall moves a plunger which is converted into a signal
- Newer technology

ADVANTAGES AND DISADVANTAGES



The Good

- Easy to install
- Very easy to maintain
- Can detect and report hail
- Simple to include in a system once configured

The Bad

- No way to calibrate
- Not very accurate
- False positives from wind
- Sensors may be covered

DROP COUNTER

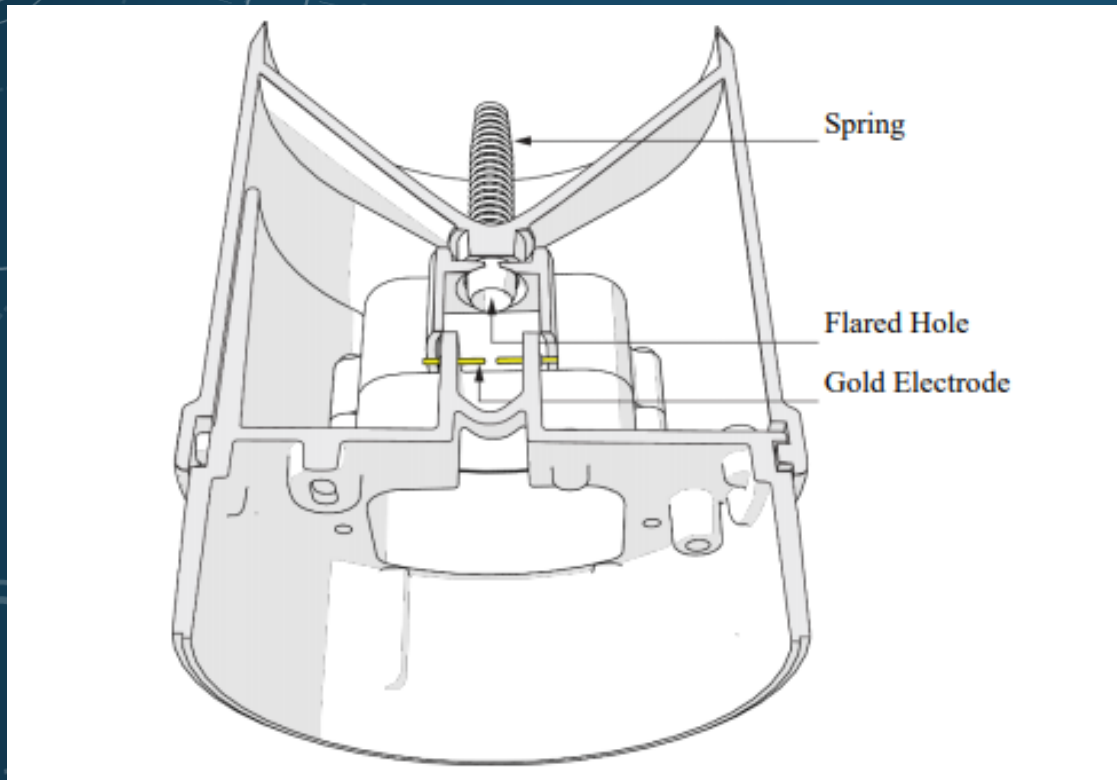

- Funnel directs towards electric sensors
- Measures each drop of water

ADVANTAGES AND DISADVANTAGES



The Good

- Cheaper measurement
- Very reliable
- Can perform calibration check
- Can still measure higher rainfall rates

The Bad

- Funnels clog
- Require regular calibration
- May not accurately measure rainfall intensity
- Less accurate than tipping bucket

RADAR DOPPLER

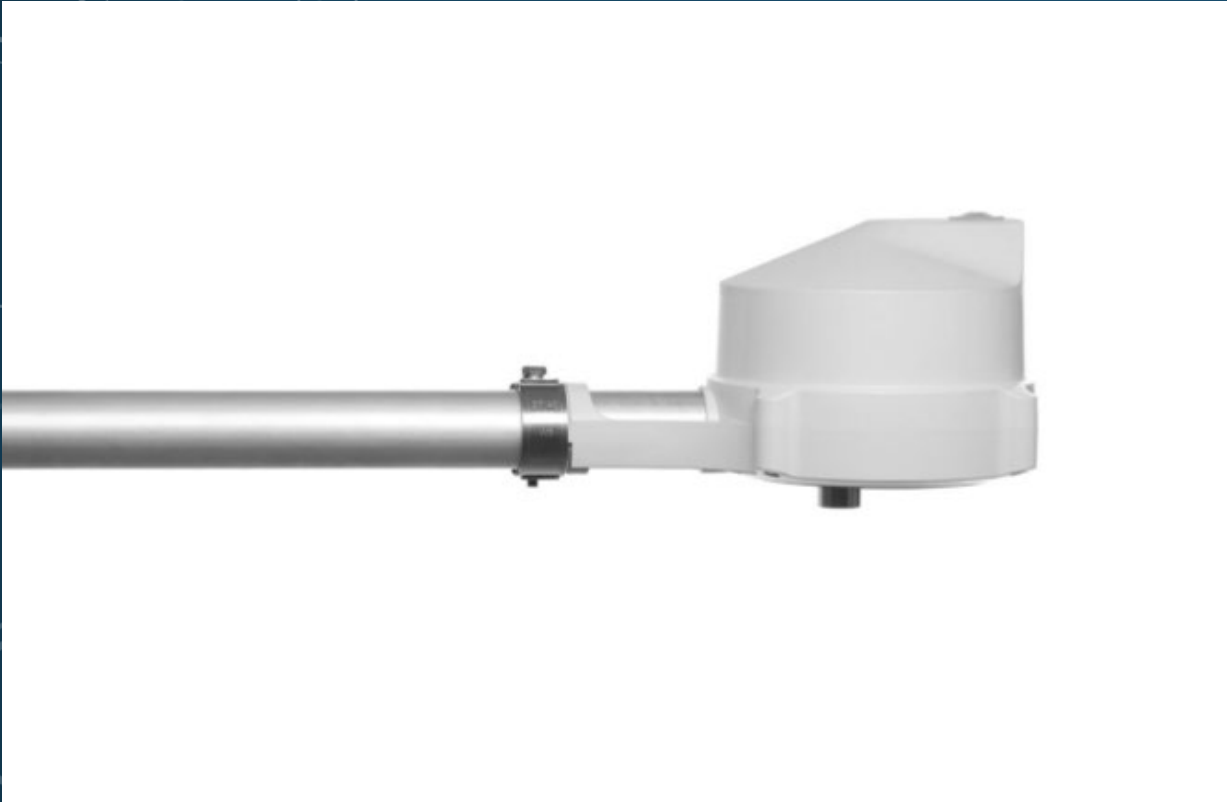

- Measures drop speed
- Correlates drop speed to drop size
- Calculations to measure total precipitation

ADVANTAGES AND DISADVANTAGES



The Good

- Very low maintenance
- Easy to install
- Provides more information than just rainfall

The Bad

- Expensive
- Higher power consumption
- Lower accuracy standard
- No way to field calibrate
- New, less tested technology

SITE EVALUATION



- Site parameters can have biggest impact
 - Trees?
 - Buildings?
 - Traffic?
 - Access for maintenance?
 - Height above ground?
 - Vandalism?
 - Wildlife?
 - Value of location?

Main components of the systematic error in precipitation measurement and their meteorological and instrumental factors listed in order of general importance

$$P_k = kP_c = k(P_g + \Delta P_1 + \Delta P_2 + \Delta P_3 \pm \Delta P_4 - \Delta P_5)$$

where P_k is the adjusted precipitation amount, k is the correction factor, P_c is the precipitation caught by the gauge collector, P_g is the measured precipitation in the gauge, and $P_1 - P_5$ are corrections for components of systematic error as defined below:

<i>Symbol</i>	<i>Component of error</i>	<i>Magnitude</i>	<i>Meteorological factors</i>	<i>Instrumental factors</i>
k	Loss due to wind field deformation above the gauge orifice	2-10% 10-50% *	Wind speed at the gauge rim during precipitation and the structure of precipitation	The shape, orifice area and depth of both the gauge rim and collector
$\Delta P_1 + \Delta P_2$	Losses from wetting on internal walls of the collector and in the container when it is emptied	2-10%	Frequency, type and amount of precipitation, the drying time of the gauge and the frequency of emptying the container	The same as above and, in addition, the material, colour and age of both the gauge collector and container
ΔP_3	Loss due to evaporation from the container	0-4%	Type of precipitation, saturation deficit and wind speed at the level of the gauge rim during the interval between the end of precipitation and its measurement	The orifice area and the isolation of the container, the colour and, in some cases, the age of the collector, or the type of funnel (rigid or removable)
ΔP_4	Splash-out and splash-in	1-2%	Rainfall intensity and wind speed	The shape and depth of the gauge collector and the kind of gauge installation
ΔP_5	Blowing and drifting snow		Intensity and duration of snow storm, wind speed and the state of snow cover	The shape, orifice area and depth of both the gauge rim and the collector



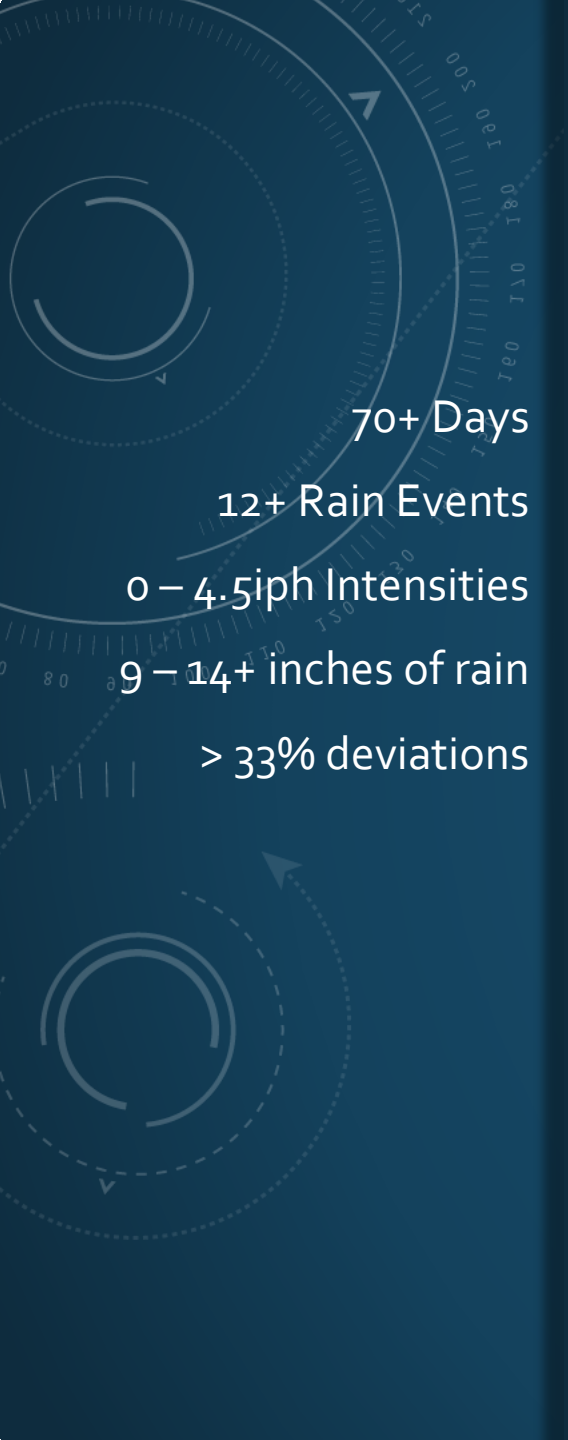

Rainfall Measurement Comparison

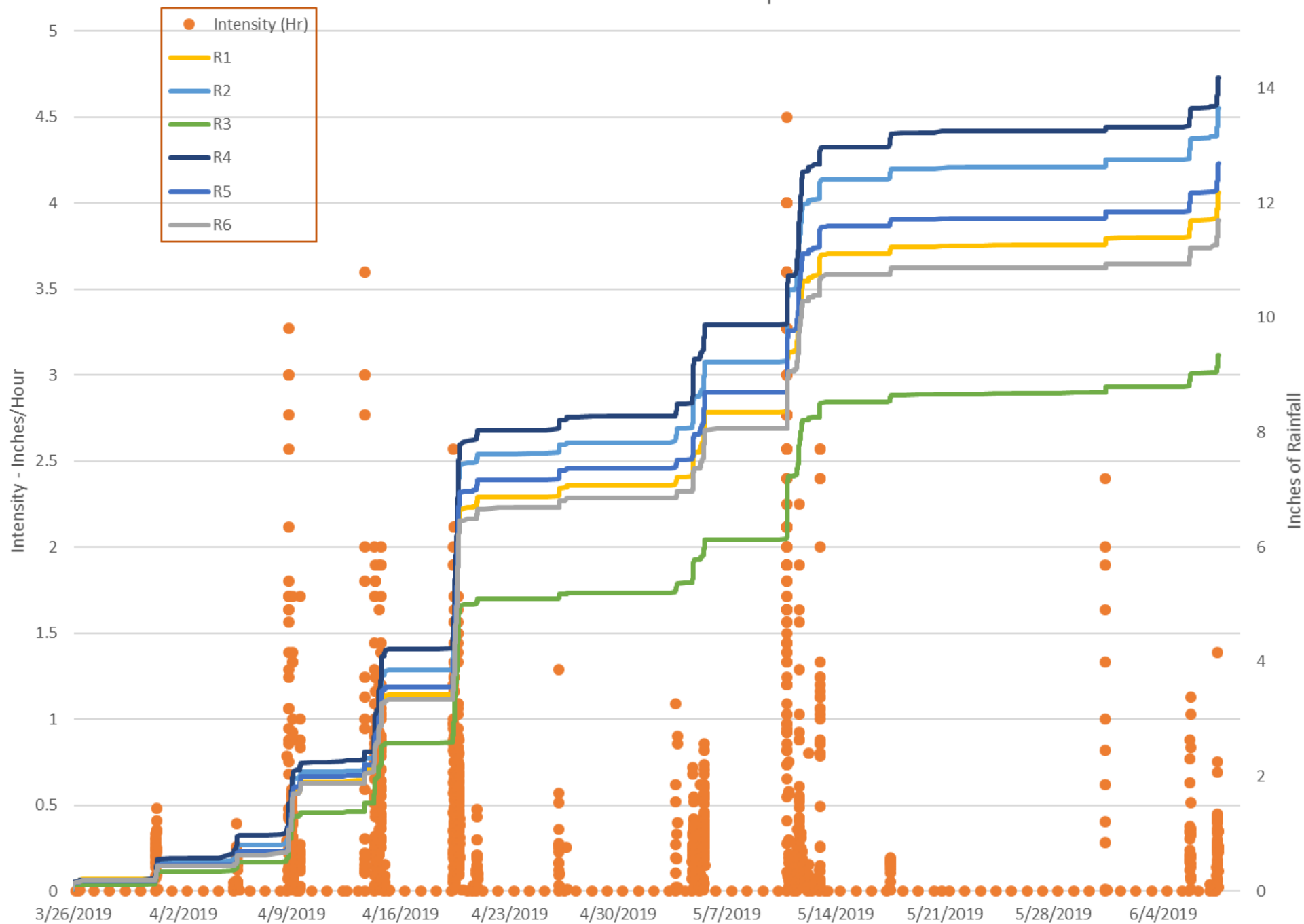



CONCLUSIONS

- Site selection and proper maintenance more impactful than sensor type
- Know the strengths and weaknesses of each sensor
- Understand how to calibrate and why it's important

“ *Grassroots rainfall reports determine what is actually happening. The more volunteers and rainfall data we have during and after an event, the better we are able to define how much it has rained and what the impacts will be on lake levels, water supply, and any areas of flooding.* ”

Jeff Lindner, HCFCD (Houston TX)

Your Measurements
Matter!

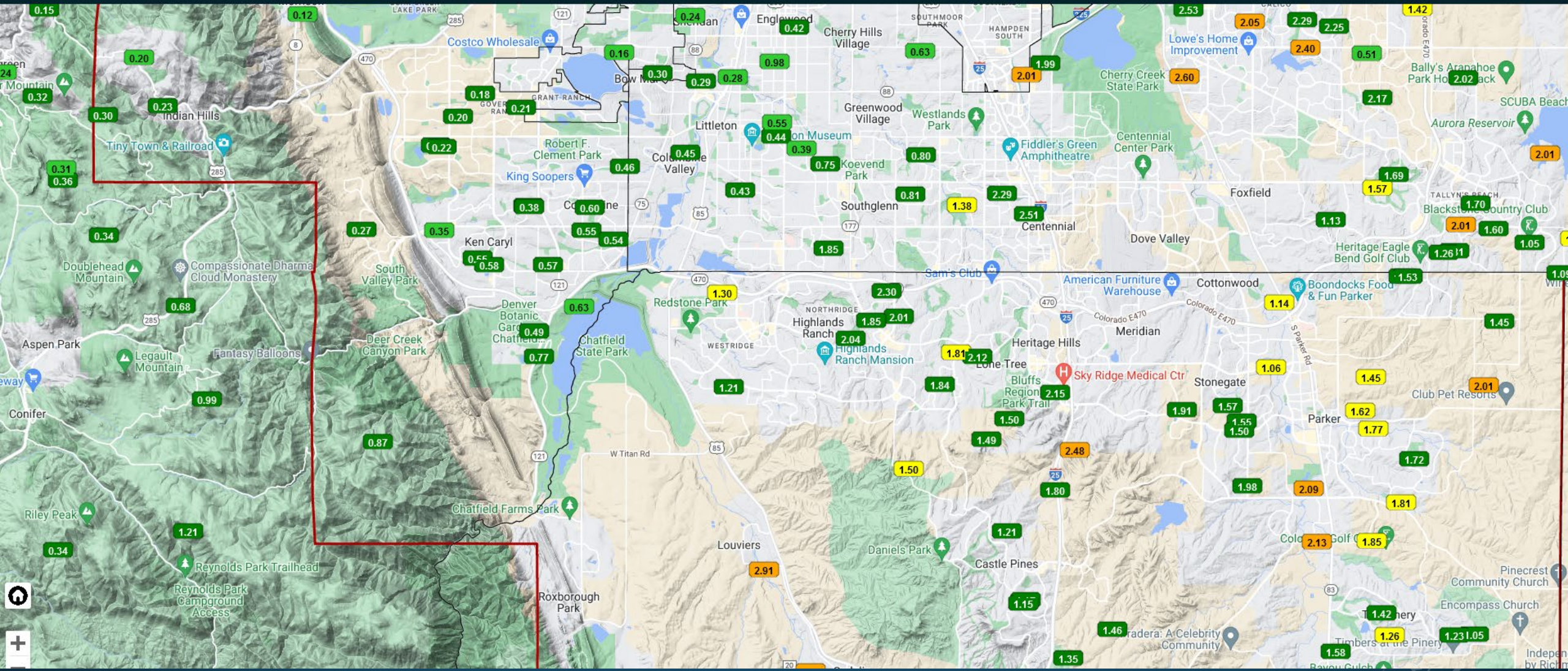

Texas Water Resources Institute
Texas Water Journal
Volume 9, Number 1, September 21, 2018
Pages 96-107

**Integration of the Community Collaborative Rain, Hail,
and Snow Network (CoCoRaHS) observations into the
West Gulf River Forecast Center operations**

COCORAHS DATA IN USE

Rainfall totals adjusted to CoCoRaHS data used in flood forecasting models

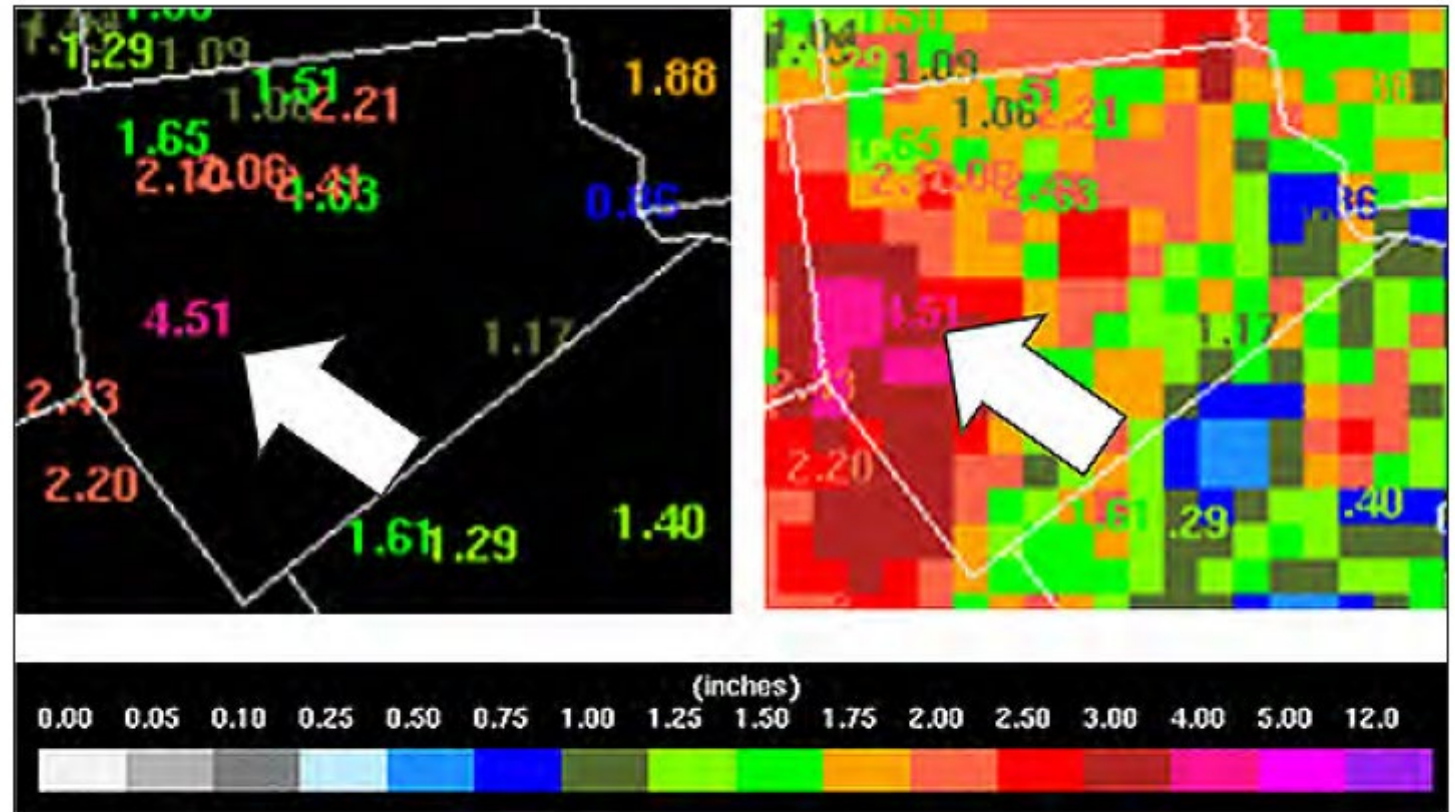

Figure 4. (Left) Location of CoCoRaHS gauge where initial underestimation was determined. Gauge values match the color scale. (Right) MPE final precipitation analysis with CoCoRaHS data overlaid after an adjustment was made to the 24-hour field. The arrow indicates where estimates were increased near Maypearl, Texas. The goal is to have the color of the MPE precipitation field match the color of the gauge reading.

LID	GAGE	MPE	LOCATION
TXFB17	: 9.60	8.63	Richmond 3.4 NE
TXGD15	: 8.92	5.35	Weser 1.9 NW
TXFB18	: 8.69	8.63	Richmond 2.9 NE
TXFB05	: 8.22	6.80	Sugar Land 3 SSE
TXFB12	: 7.61	6.74	Sugar Land 1 W
TXWH18	: 7.60	9.67	East Bernard 7.6 S
TXCLR10	: 7.50	4.99	New Ulm 5.1 S
TXCLR06	: 7.45	5.90	New Ulm 7.2 S
TXFB51	: 7.45	8.20	Richmond 4.4 NNE
TXDW19	: 7.41	5.31	Cuero 8.4 S

Figure 6. This table shows the ten highest August 26 CoCoRaHS reports. Alongside the gauge ID is the observed amount and our initial MPE estimate for that location.

LID	GAGE	MPE	LOCATION
TXGV44	: 21.62	12.90	Bacliff 0.5 SSE
TXHRR32	: 20.84	12.90	South Houston 4 SSW
TXHRR93	: 20.54	12.90	Pasadena 4.4 WNW
TXHRR31	: 19.41	12.90	Friendswood 2.5 NNE
TXGV60	: 19.38	12.90	Santa Fe 0.7 S
TXGV64	: 18.20	12.90	Hitchcock 1.6 NNW
TXHRR139	: 17.98	12.90	Cloverleaf 1.7 W
TXGV51	: 17.57	8.74	La Marque 1.8 E
TXHRR28	: 17.00	12.90	Webster 0.4 NW
TXGV63	: 16.59	12.90	Friendswood 1 SE

Figure 8. This table shows the 10 highest CoCoRaHS reports ending 12 UTC 27 August 2017. The data indicate five readings in excess of 19.25 inches that correspond to initial MPE estimates of just under 13 inches over parts of Harris and Galveston counties in southeast Texas.¹

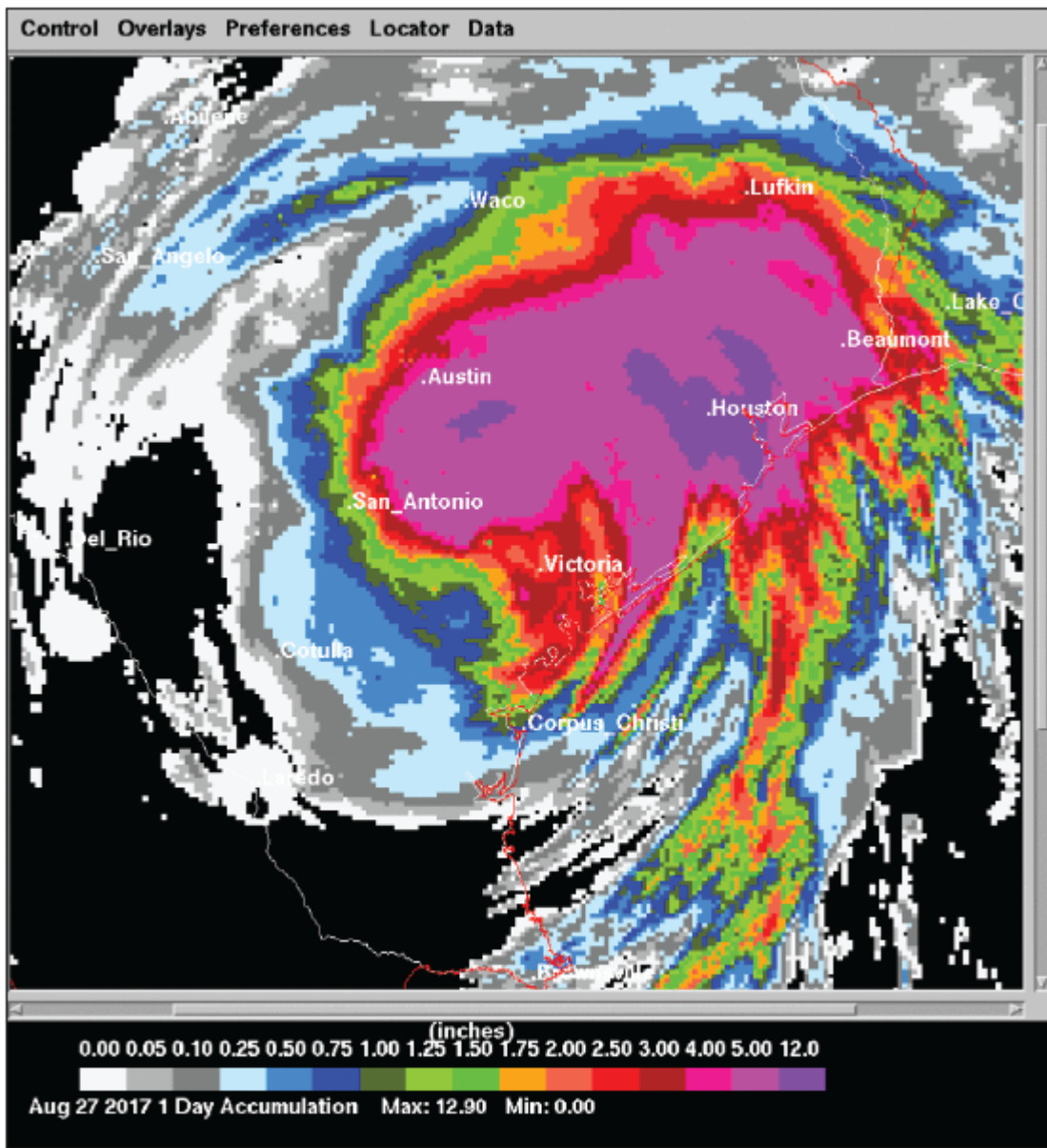

Figure 9. This was the initial estimate of rainfall from day two of Hurricane Harvey from WGRFC multisensor software.

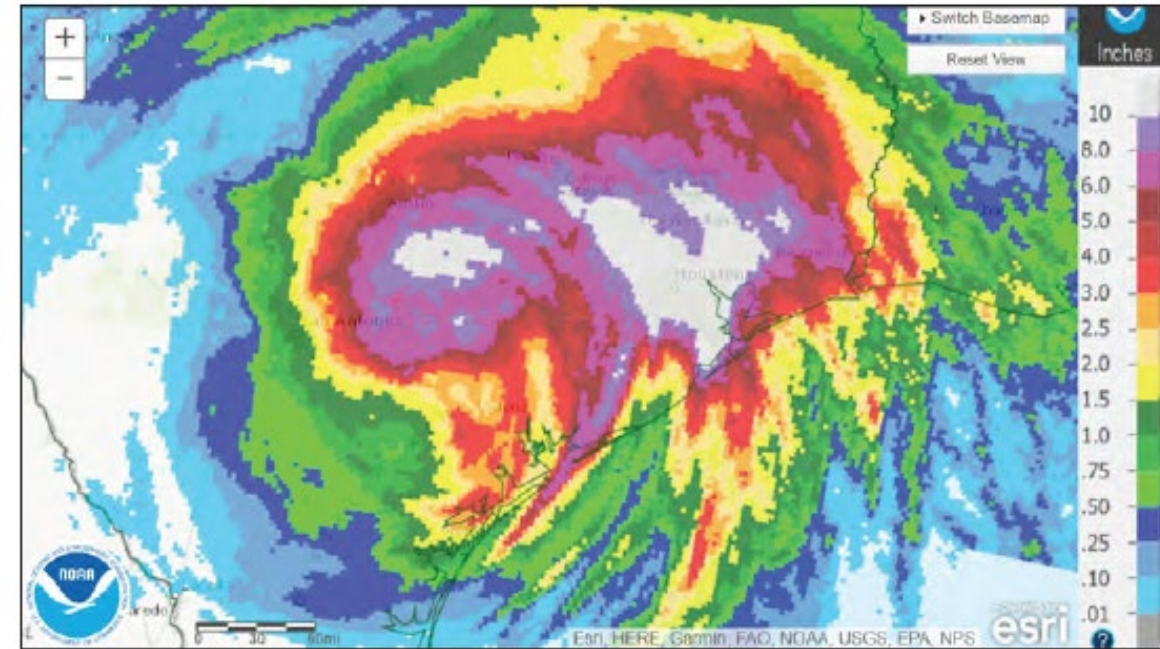

Figure 10. The final best estimate field from 12 UTC 27 August 2017. Note the sizable increase in the areal coverage of the heaviest rainfall over the initial estimates in Figure 9.



The CoCoRaHS observations helped improve the NWS lead time on the magnitude of flooding. With initial estimates biased low, adjustments were made in real time to radar precipitation totals. These CoCoRaHS readings contribute greatly to the NWS WGRFC's mission of saving lives and property from floods here in Texas. Quite often the majority of the highest ten rainfall readings in the state on any given day come from CoCoRaHS observers.



Your Measurements Matter!

Seven-Day Observed Precipitation (Inches) Ending Friday September 01, 2017 7:00 AM EDT

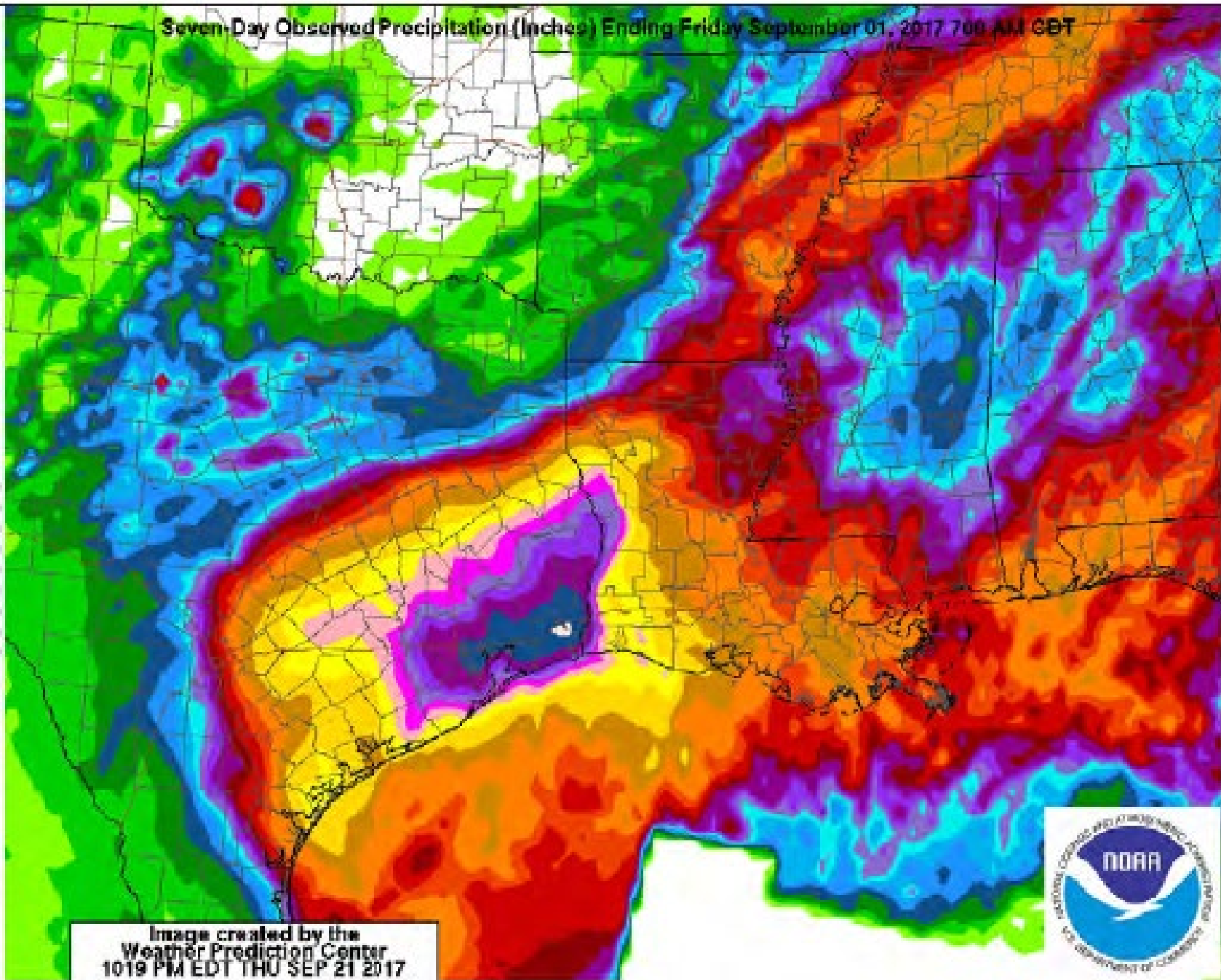

Image created by the
Weather Prediction Center
1019 PM EDT THU SEP 21 2017



Max: 62.07 inches



THANK YOU!!

Your measurements are a vital part of the NHWC and the Flood Warning Process!

mark.moore@distinctiveafwsdesigns.com

Questions?